



CBHD1 COMPACT

Main features:

Reduced weight and dimensions

Power from 30W up to 120W

Current from 2,5A to 5A

Available with Led on side or Led on top

APPLICATIONS



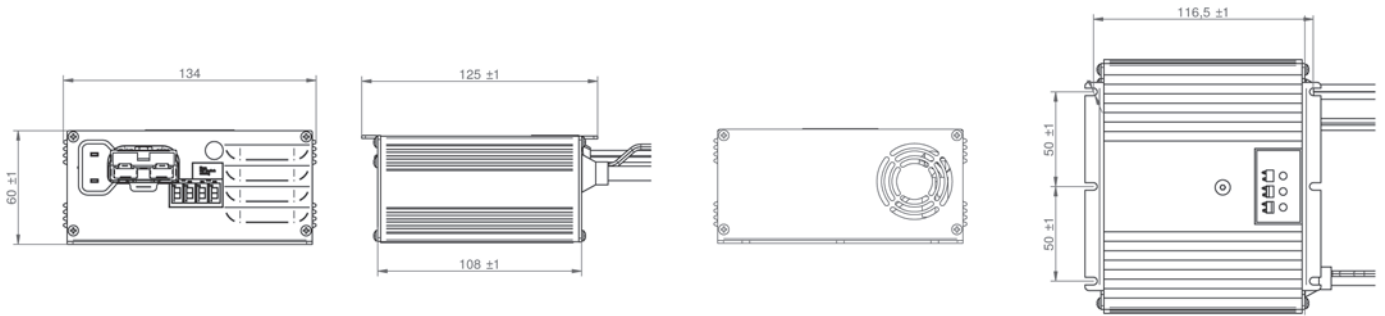

DIMENSIONS (LxWxH): 134x125x60 mm - 5.28x4.92x2.36 in

WEIGHT: 1,20 Kg - 2.65 lbs

PROTECTION GRADE IP30

INPUT VOLTAGE: Universal 100 ÷ 240 Vac – 50-60 Hz

Battery Voltage	Battery Range		Charging Current	Model
	5h	20h		
12V	10 ÷ 25 Ah	15 ÷ 30 Ah	2,5A	12-2,5
	20 ÷ 50 Ah	30 ÷ 60 Ah	5A	12-5
24V	10 ÷ 25 Ah	15 ÷ 30 Ah	2,5A	24-2,5
	20 ÷ 50 Ah	30 ÷ 60 Ah	5A	24-5

