

SPG Series

SPG12-490W 12V135Ah



UPS LAB
 Официальный дилер в РФ
 www.UPS-LAB.ru
 +7 (495) 109-90-77

SPG series VRLA battery uses AGM technology and high-purity raw materials. It has good high power discharge, floating backup and fast charging performance. It is mainly used in UPS/EPS standby power supply systems. It can backup power in poor operation environment.



Benefits

- Long life according to EUROBAT Classification
- Maximum charge efficiency
- High gas recombination efficiency
- Low self-discharge rate
- Horizontal or vertical installization

Applications

- UPS units
- Data center
- Starting generators
- EPS units

Drawing

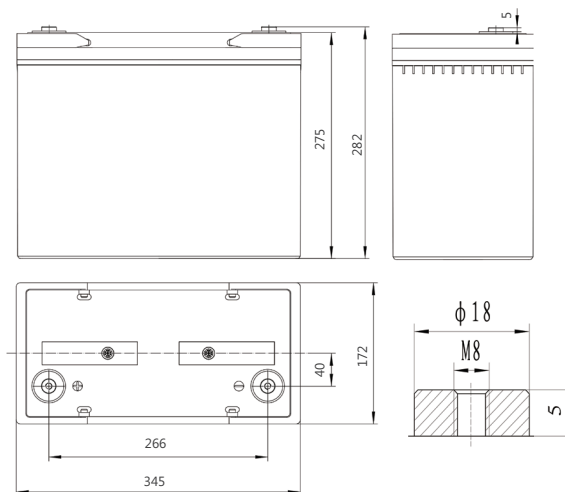

SP-29

Standards

- IEC 60896-21/22
- JIS C8704-1/2
- EUROBAT guide

Specifications

Battery Model	SPG12-490W			
Design Life (years, 25°C)	12			
Capacity (Ah, 25°C)	10min (1.60V)	15min (1.67V)	1HR (87.6A, 1.70V)	10HR 13.5A, 1.80V)
	642W/cell	490W/cell	87.6Ah	135Ah
Dimensions (mm)	Length	Width	Height	Total Height
	345	172	275	282
Approx. Weight (kg)	42.5			
Reference Internal Resistance (mΩ)	3.6 (fully charged @ 25°C)			
Maximum Discharge Current (A/5 Sec.)	1485			
Self-Discharge (25°C)	≤ 2% per months			
Charge Voltage (V/cell, 25°C)	Cycle use		Float use	
	2.40(-3.5mV/°C/cell), max charge current: 40.5A		2.27(-3.5mV/°C/cell)	
Short Circuit Current (A)	3300			

Discharge Data

Constant Current Discharge Data (25°C, A)														
End Voltage (V/cell)	min							h						
	5	10	15	20	25	30	45	1	1.5	2	3	5	6	10
1.60	440	340	279	226	192	166	116	94.1	73.5	56.7	39.5	24.8	21.1	14.1
1.65	416	327	269	219	186	161	113	91.2	71.8	55.6	38.3	24.4	20.9	14.0
1.67	397	316	260	213	180	156	110	89.4	70.4	54.5	37.6	24.1	20.6	13.9
1.70	387	306	251	207	174	152	108	87.6	69.2	53.7	36.9	23.7	20.5	13.8
1.75	366	288	241	196	166	146	103	85.0	67.1	52.3	35.8	23.5	20.2	13.6
1.80	341	268	226	185	158	138	98.5	81.5	64.6	50.6	34.3	22.8	19.9	13.5

Constant Power Discharge Data (25°C, W/cell)														
End Voltage (V/cell)	min							h						
	5	10	15	20	25	30	45	1	1.5	2	3	5	6	10
1.60	770	642	524	426	367	338	237	199	149	113	77.3	52.4	45.9	28.8
1.65	731	615	510	413	360	331	232	193	144	110	75.0	52.1	45.2	28.4
1.67	712	592	490	399	353	325	227	189	140	107	73.5	50.3	44.1	27.8
1.70	691	570	474	384	340	317	223	186	137	106	71.9	49.8	43.7	27.4
1.75	667	546	457	370	329	308	219	180	133	104	70.7	48.9	42.7	26.9
1.80	642	520	437	354	317	296	212	173	130	101	69.4	47.4	41.6	26.1

Performance Curve

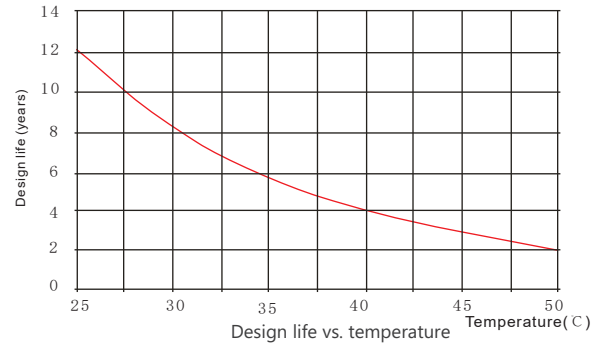
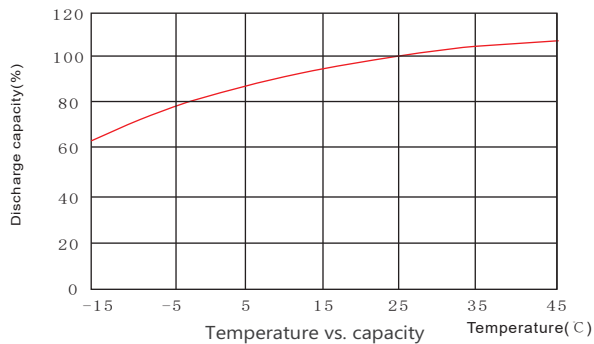
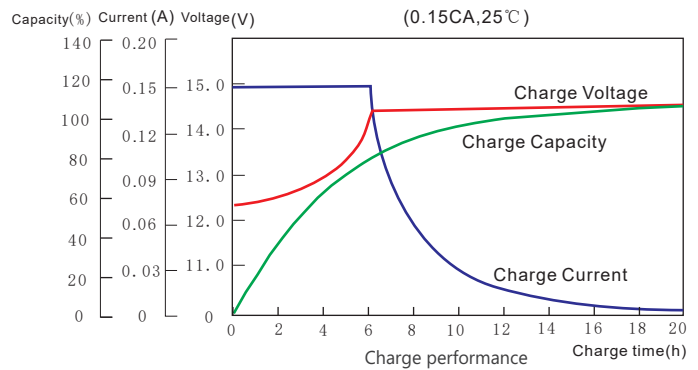
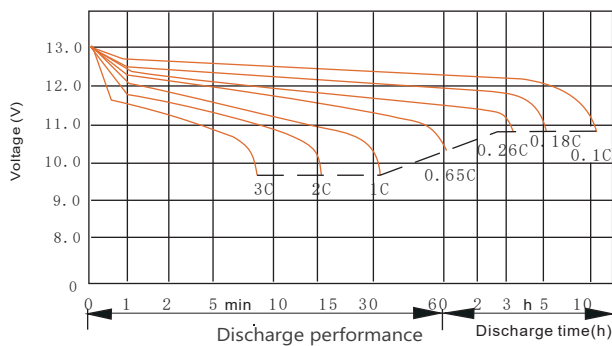

Sacred Sun Power Sources Co., Ltd.

No.1 Shengyang Road Qufu City, PRC
sales@sacredsun.cn

Sacred Sun Asia Pacific

No. 15, Yishun Industrial Street 1,
#01-17, WIN5, Singapore 768091
sales.asia@sacredsun.cn

Sacred Sun Europe SPRL

Paul Dejaerlaan 4b, B 1060 Brussel,
Belgium
sales.eu@sacredsun.cn

Sacred Sun MEA FZE

Jebel Ali, Dubai, UAE
sales.mea@sacredsun.cn