

Operating Manual (English)

Long tiller arm for Travel 503/1003

(Item No. 1919-00)

Delivery scope:

- long tiller arm with connecting pin and diametral magnet
- Tiller handle
- Mounting instruction
- Packaging
- Warranty certificate

Disassembly

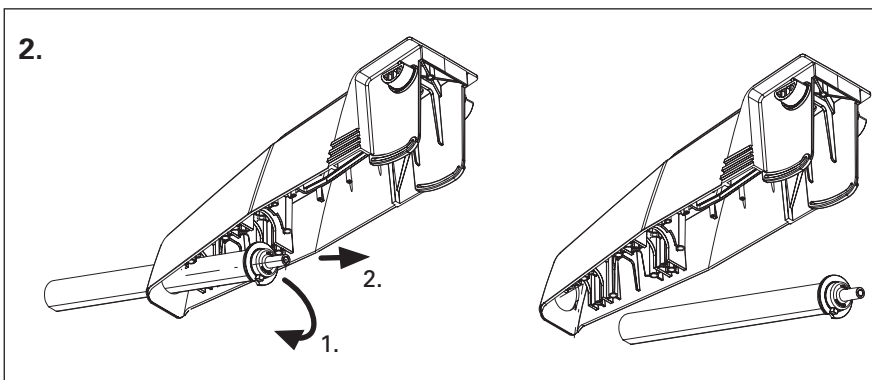
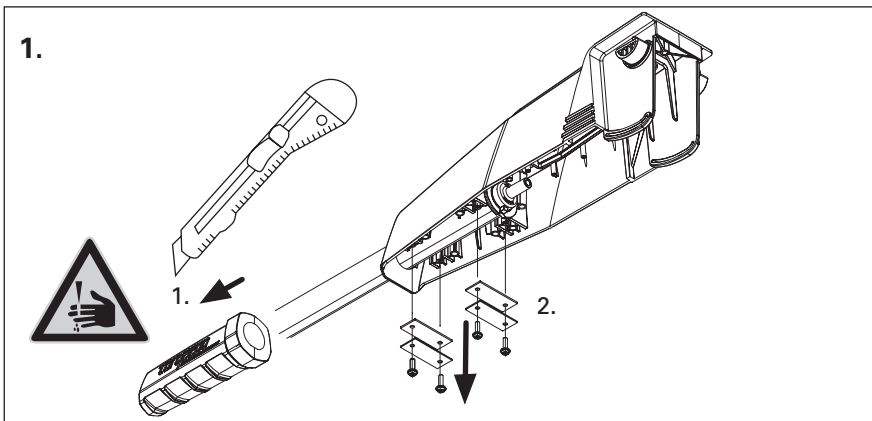

Assembly

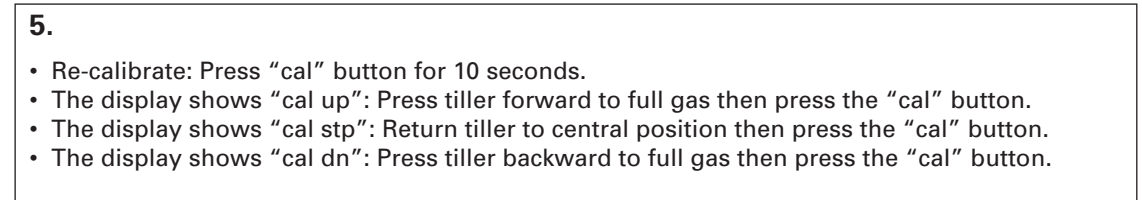
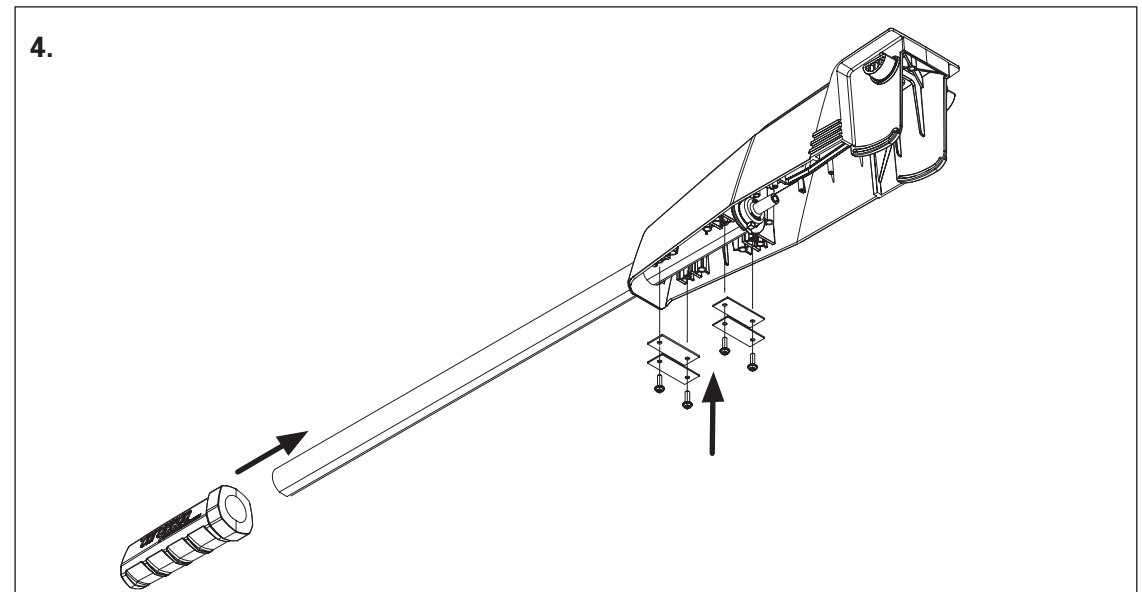
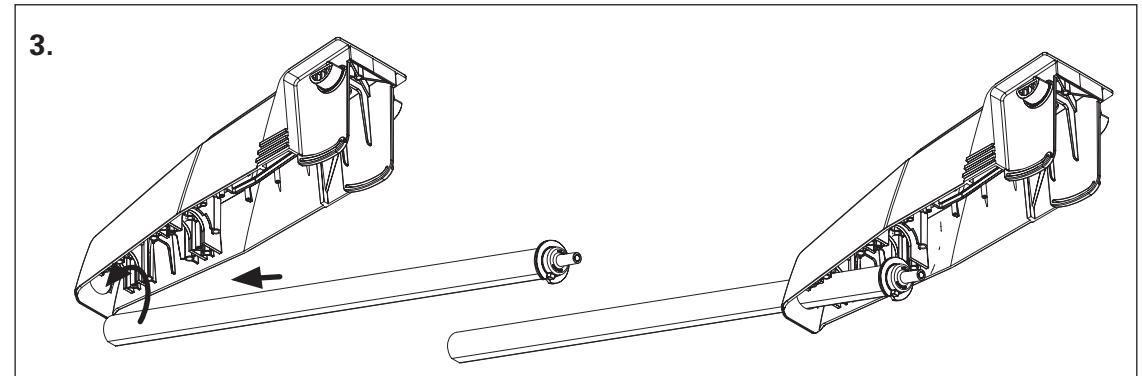

Warranty terms

Extent of warranty

Torqeedo GmbH, Petersbrunner Straße 3a in D-82319 Starnberg, Germany, guarantees the final purchaser of this product that the product is free from material and manufacturing faults during the period stated below. Torqeedo will indemnify the final purchaser for any expense for the repair of a material or manufacturing fault. This indemnification obligation does not cover the incidental costs of a warranty claim or any other financial losses (e.g. costs for towing, telecommunications, food, accommodation, loss of earnings, loss of time etc.).

The warranty ends two years after the date on which the product was delivered to the final purchaser. Products that are used commercially or by public authorities - even if only temporarily - are excluded from this two-year warranty. In these cases, the statutory warranty applies. The right to claim under warranty runs out six months after discovery of a fault.

Torqeedo decides whether faulty parts are repaired or replaced. Distributors and dealers who repair Torqeedo products have no authority to make legally binding statements on behalf of Torqeedo.

Normal wear and tear and routine servicing are excluded from the warranty.

Torqeedo is entitled to refuse a warranty claim if

- the warranty was not correctly submitted (refer to the warranty process),
- the product was not treated in accordance with the instructions,
- the safety, operating and care instructions in the manual were not observed,
- the product was in any way altered or modified or parts and accessories were added that are not expressly permitted or recommended by Torqeedo,

- previous maintenance or repairs were not undertaken by organizations authorized by Torqeedo or parts that were not original spare parts were used unless the end user can prove that the facts that justify rejecting the warranty claim did not favor the development of the fault. As well as the rights arising from this warranty, the customer also has legal warranty claim rights arising from the purchase contract with the dealer that are not hampered by this warranty.

Warranty process

Adhering to the following warranty process is a prerequisite to the satisfaction of any warranty claims.

Before dispatching any apparently faulty goods, it is imperative to coordinate the delivery with Torqeedo Services. You can contact us by phone, email or post. The ability to make contact via the www.torqeedo.com website is being extended successively. **Please understand that we are unable to deal with products of which we have not been notified and will therefore refuse to accept delivery.**

To check a warranty claim and to process a warranty, we require a completed **warranty certificate** as well as **proof of purchase**.

- The warranty certificate attached must show contact details, product details, serial number, and a brief description of the problem.
- Proof of purchase must indicate the purchase and the date of purchase (e.g. transaction receipt, invoice or receipt).

For returning the product to the Service Center, we recommend keeping the original Torqeedo packaging. If this is no longer available packaging that excludes transport damage must be used as this is not included in the warranty.

We are available to answer any questions regarding the warranty process - simply use the contact details.

Torqeedo Service Center

Europe and international

Torqeedo GmbH
- Service Center -
Friedrichshafener Straße 4a
82205 Gilching
Germany

service@torqeedo.com
T +49 - 8153 - 92 15 - 100
F +49 - 8153 - 92 15 - 319

North America

Torqeedo Inc.
171 Erick Street, Unit A-1
Crystal Lake, IL 60014
USA

service_usa@torqeedo.com
T +1 - 815 - 444 88 06
F +1 - 847 - 444 88 07

All other countries:

Contact details of international Service Centers are available under www.torqeedo.com in the "Service" section.